



Installation Instructions for KPMI Part No: **30-33450**

Honda CRF 450X • 2005- '17

Cylinder Head Service Kit

This kit is verified for the model year range listed above. Certain components in this kit may have larger coverage and are labeled accordingly. When installing KPMI Cylinder Head Service Kits it is important to maintain these highly stressed components in accordance with factory service limits. Always consult with qualified professionals suited to inspect your machine.

A) 30-33450 Kit Includes

Note: (Intake and Exhaust parts are **NOT** interchangeable)

KPMI P/N	QTY	Description	Specification
30-31050	1 Set	Spring Kit	Includes: Titanium Retainers, CrSi Valve Springs*, HT Steel Basewashers
30-31062	2 Pcs.	Intake, Standard Valve	Valve • Black Diamond™ • Black Nitroreg Stems
30-31066	2 Pcs.	Exhaust, Standard Valve	Valve • Black Diamond™ • Black Nitroreg Stems
30-31070	2 Pcs.	Intake, Standard Valve Guide	Valve Guide • Mng. Brz. Bronze
30-31080	2 Pcs.	Exhaust, Standard Valve Guide	Valve Guide • Mng. Brz. Bronze
30-33451	1 Set	Gasket Kit	Includes: Head Gasket 96mm Bore (1), Exhaust Valve Seals (2), Intake Valve Seals (2), Base Gasket (1), Cam Chain Tensioner Gasket (1), Exhaust Gasket (1), Water Outlet O-ring (1)

*The Exhaust Springs for this kit include progressively wound Inner Springs, which should be installed with the tightly wound end seated on the HT Steel Basewashers.

B) Recommended Installed Height - Intake

- | | |
|-------------------------------------|------------------------|
| 1. Installed Height | 1.210" - 1.220" |
| 2. Seat Pressure | 40 # |
| 3. Open Pressure at .375 lift | 131 # |
| 4. Open Pressure at .440 lift | 147 # |
| 5. Max Valve Lift | 0.440" |

Recommended Installed Height - Exhaust

- | | |
|-------------------------------------|------------------------|
| 1. Installed Height | 1.360" - 1.370" |
| 2. Seat Pressure | 70 # |
| 3. Open Pressure at .375 lift | 183 # |
| 4. Open Pressure at .440 lift | 203 # |
| 5. Max Valve Lift | 0.440" |

C) Notes

1. The difference between the installed height and the coil bind height is considered "Free-Travel"

The coil bind height is determined by compressing the spring or springs with the retainer and basewasher in place, a vice can be used for this operation, once springs are compressed measure the distance between the retainer and basewasher where the outer spring contacts them.
2. Free-travel should always be gross valve lift +.060" for safe operation.
3. Retainer to seal and retainer to guide clearance should also be gross valve lift +.060" for safe operation.
4. Failure to check valve train clearances can result in serious damage to an engine

Packaged By: _____

Date: _____

TECH TIPS

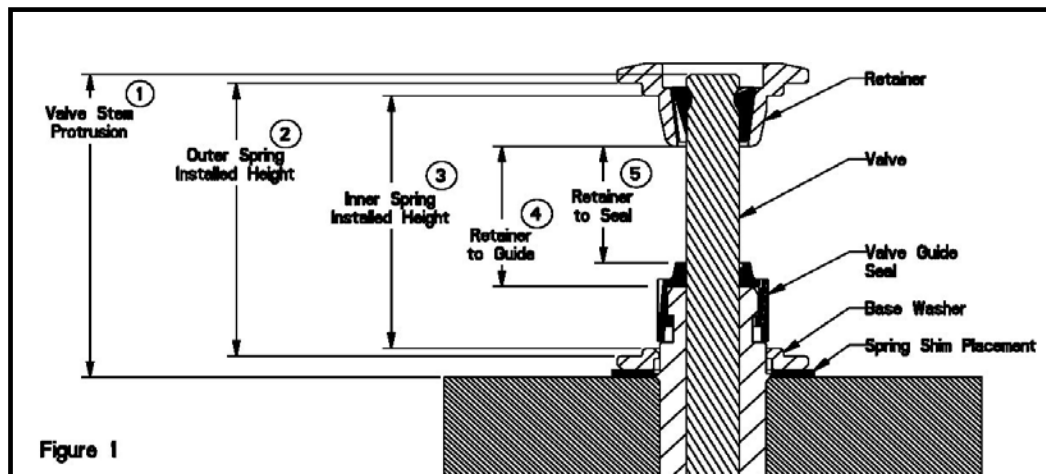

Figure 1

Valve Train Terminology

1. Stem Protrusion is measured from the tip of the valve stem to the cylinder head. See Figure 1.
2. Outer spring installed height is measured where the outer spring contacts the retainer and lower component when assembled. See Figure 1.
3. Inner spring installed height is measured where the inner spring contacts the retainer and lower component when assembled. See Figure 1.
4. Retainer to guide clearance is the distance between the valve guide (w/o the seal) and the bottom of the retainer, with the valve in the closed position. See Figure 1 and Notes 3 & 4.
5. Retainer to seal clearance is the distance between the valve stem seal and the bottom of the retainer, with the valve in the closed position. See Figure 1 and Notes 3 & 4.

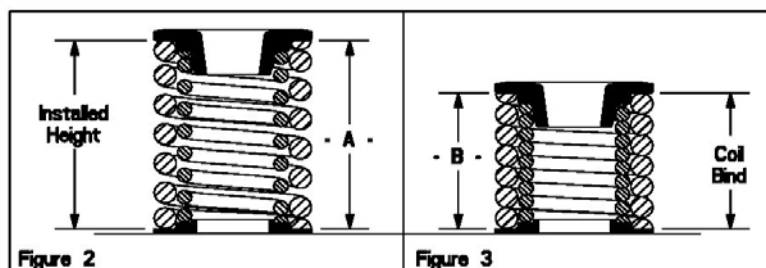

Figure 2

Figure 3

Installed Height

1. In Figure 2 the installed height is measured from where the outer spring contacts the retainer and the basewasher. This measurement is taken when the valve, basewasher, retainer, and keepers are assembled in the cylinder head.

Coil Bind / Solid Height:

1. In Figure 3 the coil bind height is determined by compressing the spring or springs with the retainer and basewasher in place, a vice can be used for this operation, once springs are compressed measure the distance between the retainer and basewasher where the outer spring contacts them.

Notes:

1. The difference between the installed height and the coil bind height is considered "Free-Travel"
2. Free-travel should always be gross valve lift +.060" for safe operation.
3. Retainer to seal and retainer to guide clearance should also be gross valve lift +.060" for safe operation.
4. Failure to check valve train clearances can result in serious damage to an engine.