



## Installation Instructions for KPMI Part No: **60-60045**

Suzuki • Various 400's

DR-Z400E / S / SM • 2000-'19

LT-Z400 / 400Z • 2003-'18

Lightweight Racing Valve Spring Kit

### A) 60-60045 Kit Includes

<u>Qty</u>	<u>Application</u>	<u>Description</u>
4 - Pcs	In/Ex	Titanium Retainers
4 - Prs	In/Ex	Chrome Silicon Springs
4 - Pcs	In/Ex	H.T. Steel Basewashers

### B) Recommended Installed Height - Intake/Exhaust

1. Installed Height .....	<b>1.200"-1.210"</b>
2. Seat Pressure .....	<b>57#</b>
3. Open Pressure at .300" valve lift .....	<b>135#</b>
4. Open Pressure at .440" valve lift .....	<b>171#</b>
5. Max Valve Lift .....	<b>0.440"</b>

### C) Notes

1. The difference between the installed height and the coil bind height is considered "Free-Travel"

The coil bind height is determined by compressing the spring or springs with the retainer and basewasher in place, a vice can be used for this operation, once springs are compressed measure the distance between the retainer and basewasher where the outer spring contacts them.

2. Free-travel should always be gross valve lift +.060" for safe operation.
3. Retainer to seal and retainer to guide clearance should also be gross valve lift +.060" for safe operation.
4. Failure to check valve train clearances can result in serious damage to an engine

Packaged By: \_\_\_\_\_

Date: \_\_\_\_\_

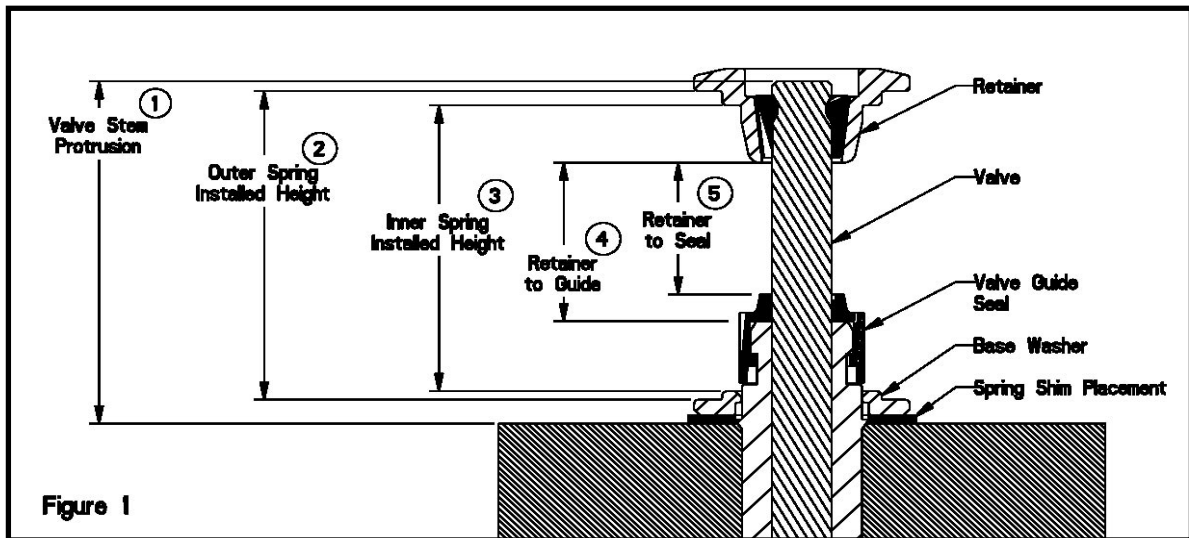
**TECH TIPS****Figure 1****Valve Train Terminology**

1. Stem Protrusion is measured from the tip of the valve stem to the cylinder head. See Figure 1.
2. Outer spring installed height is measured where the outer spring contacts the retainer and lower component when assembled. See Figure 1.
3. Inner spring installed height is measured where the inner spring contacts the retainer and lower component when assembled. See Figure 1.
4. Retainer to guide clearance is the distance between the valve guide (w/o the seal) and the bottom of the retainer, with the valve in the closed position. See Figure 1 and Notes 3 & 4.
5. Retainer to seal clearance is the distance between the valve stem seal and the bottom of the retainer, with the valve in the closed position. See Figure 1 and Notes 3 & 4.

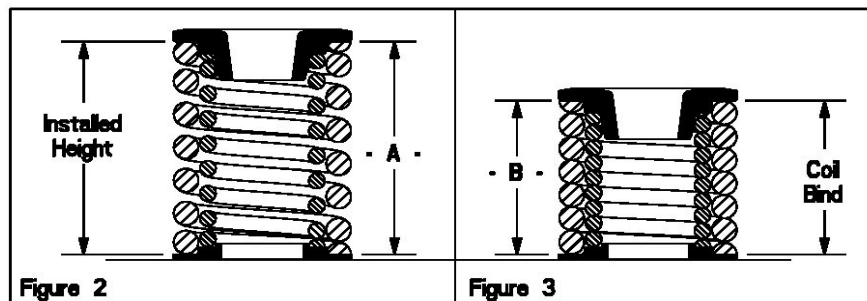
**Figure 2****Figure 3****Installed Height**

1. In Figure 2 the installed height is measured from where the outer spring contacts the retainer and the basewasher. This measurement is taken when the valve, basewasher, retainer, and keepers are assembled in the cylinder head.

**Coil Bind / Solid Height:**

1. In Figure 3 the coil bind height is determined by compressing the spring or springs with the retainer and basewasher in place, a vice can be used for this operation, once springs are compressed measure the distance between the retainer and basewasher where the outer spring contacts them.

**Notes:**

1. The difference between the installed height and the coil bind height is considered "Free-Travel"
2. Free-travel should always be gross valve lift +.060" for safe operation.
3. Retainer to seal and retainer to guide clearance should also be gross valve lift +.060" for safe operation.
4. Failure to check valve train clearances can result in serious damage to an engine.